

Operating  
and  
Service  
Manual

HP 8485A  
Power Sensor

---

## **NOTICE**

The information contained in this document is subject to change without notice.

HEWLETT-PACKARD MAKES NO WARRANTY OF ANY KIND WITH REGARD TO THIS MANUAL, INCLUDING, BUT NOT LIMITED TO, THE IMPLIED WARRANTIES OF MERCHANTABILITY AND FITNESS FOR A PARTICULAR PURPOSE. Hewlett-Packard shall not be liable for errors contained herein or direct, indirect, special, incidental or consequential damages in connection with the furnishing, performance, or use of this material.

## **WARRANTY**

A copy of the specific warranty terms applicable to your Hewlett-Packard product and replacement parts can be obtained from your local Sales and Service Office.

## **Herstellerbescheinigung**

Hiermit wird bescheinigt, daß dieses Gerät/System in Übereinstimmung mit den Bestimmungen von Postverfügung 1046/84 funkentstört ist.

Der Deutschen Bundespost wurde das Inverkehrbringen dieses Gerätes/System angezeigt und die Berechtigung zur Überprüfung der Serie auf Einhaltung der Bestimmungen eingeräumt.

Zusatzinformation für Meß- und Testgeräte:

Werden Meß- und Testgeräte mit ungeschirmten Kabeln und/oder in offenen Meßaufbauten verwendet so ist vom Betreiber sicherzustellen, daß die Funkentstörbedingungen unter Betriebsbedingungen an seiner Grundstücksgrenze eingehalten werden.

## **Manufacturer's Declaration**

This is to certify that this equipment is in accordance with the Radio Interference Requirements of Directive FTZ 1046/1984. The German Bundespost was notified that this equipment was put into circulation, and has been granted the right to check the equipment type for compliance with these requirements.

**Note:** If test and measurement equipment is operated with unshielded cables and/or used for measurements in open setups, the user must ensure that under these operating conditions, the radio frequency interference limits are met at the border of his premises.

**General Information**

This Operating and Service Manual contains information about initial inspection, performance tests, adjustments, operation, troubleshooting and repair of the HP 8485A Power Sensor.

**Instruments Covered by Manual**

This instrument has a two-part serial number. The first four digits and the letter comprise the serial number prefix. The last five digits form a sequential suffix which is unique to each instrument. The contents of this manual apply directly to instruments having the serial number prefix 2942A and below.

If your instrument has a serial number prefix less than 2942A additional information is located in the "Backdating" section at the end of this manual. If your instrument has a serial number prefix greater than 2942A look for a yellow "Manual Changes" supplement that documents the difference.

In addition to change information, the supplement may contain information for correcting errors in the manual. The supplement is keyed to the manual print date and part number, both of which appear on the front cover.

For information concerning a serial number prefix not listed here, in "Backdating" or in the "Manual Changes" supplement, contact your nearest Hewlett-Packard office.

**Description**

The HP 8485A Power Sensor is a thermocouple power sensor. The standard Power Sensor measures power levels in a range from  $-30$  dBm to  $+20$  dBm ( $1 \mu\text{W}$  to  $100 \text{ mW}$ ) at frequencies from  $50 \text{ MHz}$  to  $26.5 \text{ GHz}$ . The HP 8485A Option 033 has an extended frequency range to  $33 \text{ GHz}$ . (Specifications for the Power Sensor are in Table 1.) The Power Sensor contains two thermocouples on a silicon chip. The thermal/mechanical layout of the thermocouple is selected to give a hot junction at the resistor (center of the chip) and a cold junction at the outer edge of the chip.

When the resistor at the hot junction converts the applied microwave energy to heat, the temperature difference between the hot and cold junctions generates a dc voltage (thermoelectric emf). The dc voltage is proportional to the temperature difference between the junctions and, therefore, proportional to the power from the rf source. The dc voltage thus generated is a very low-level voltage (approximately  $160 \text{ nV}$  for  $1 \mu\text{W}$  applied power) and requires amplification before it can be transferred on standard cables.

The amplification is provided by an input amplifier assembly which consists of a chopper (sampling gate) and an input amplifier. The dc voltage is routed on gold wires to the chopper circuit which converts the low-level dc voltage to an ac voltage. To do this, the chopper uses two field effect transistors (FETs) controlled by a 220 Hz square wave. The result is an ac output signal proportional to the dc input. The ac signal is then amplified by the input amplifier. The relatively high-level ac signal output can now be routed by standard cables.

In application, the Power Sensor is connected between an rf source and a compatible power meter. (Suitable meters are the HP 435B, 436A, 437B, 438A, and 70100A Power Meters which generate the necessary 220 Hz square wave.) The Power Sensor provides a 50 ohm load for the rf source. This load is determined by the thermocouples which are each 100 ohms and are in parallel to the RF source. The very low SWR to 26.5 GHz is possible because of the low parasitics of the thermocouple chip and the constant impedance transition from coax to the thermocouple chip. The power meter indicates the power dissipated in these thermocouples in +W (or mW) or in dBm.

**Table 1. Specifications**

<b>Frequency Range:</b> 50 MHz to 26.5 GHz
<b>Frequency Range Option 033:</b> 50 MHz to 33 GHz
<b>Power Measurement Range:</b> - 30 dBm to +20 dBm (1 $\mu$ W to 100 mW )
<b>Maximum Permissible RF Power, Average:</b> 300 mW
<b>Maximum Permissible RF Power, Peak:</b> 15W
<b>Maximum Energy Pulse:</b> 30 W $\cdot$ $\mu$ s
<b>Nominal Impedance:</b> 50 $\Omega$
<b>Maximum SWR (Reflection Coefficient) of Power Sensor:</b>
1.15 (0.070) 50 to 100 MHz
1.10 (0.048) 100 MHz to 2 GHz
1.15 (0.070) 2 to 12.4 GHz
1.20 (0.091) 12.4 to 18 GHz
1.25 (0.111) 18 to 26.5 GHz
(Opt. 033) 1.40 (0.166) 26.5 to 33 GHz
<b>Connector:</b> 3.5 mm Male
<b>Operating Temperature:</b> 0 to 55°C
<b>Calibration:</b> Individual calibration graph and table, provided with each Power Sensor
<b>Dimensions, Including RF Connector:</b> 40 mm wide, 30 mm high, 95 mm long (1.5 in. x 1.25 in. x 4 in.)
<b>Weight:</b> Net, 0.2 kg (8 oz)
<sup>1</sup> <b>Power Linearity:</b> +10 to +20 dBm (+2, -4%)

<sup>1</sup> Negligible deviation except for those power ranges noted

**Calibration Factor**

The CAL FACTOR data is provided on a data sheet and a label attached to the cover. Maximum uncertainties of the CAL FACTOR data are listed in Table 2.

**Table 2. HP 8485A Calibration Factor  
Uncertainty at 1 mW**

Frequency(GHz)	(RSS) Probable Uncertainty (%)	Worst Case Uncertainty (%)
1.0 GHz	1.6%	3.9%
2.0	1.6	4.2
4.0	1.7	4.3
6.0	1.8	4.5
8.0	1.9	4.6
10.0	2.0	4.8
12.0	2.0	4.9
14.0	2.2	5.6
16.0	2.3	5.5
18.0	2.0	5.6
22.0	2.1	5.7
26.5	2.1	5.3
33	2.4	7.1

**Option 033**

The HP 8485A Option 033 is calibrated to measure power levels in the 50 MHz to 33 GHz frequency range. In all other respects, it is the same as the standard HP 8485A Power Sensor.

**Accessory**

The Power Sensor is supplied with a Type N to 3.5 mm 50 ohm coaxial adapter (HP 08485-60005, shown in Figure 1). This accessory should be used for 50 MHz calibration only.

An HP 8485A Option 003 does not have the adapter.

**Caution**

Do not apply torque to the Power Sensor's body while connecting or disconnecting the type N to 3.5 mm adapter.

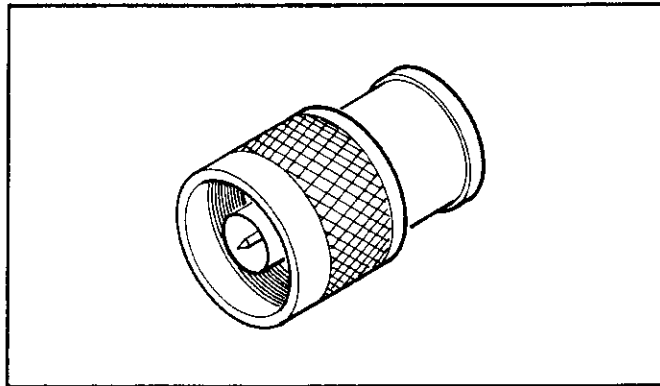

Figure 1. Type N to 3.5 mm Coaxial Adapter

**Option 003**

The Option 003 deletes the Type N male to 3.5 mm female adapter.

**Recommended Test Equipment**

Table 3 lists the test equipment recommended to check, adjust, and troubleshoot the Power Sensor. If substitute equipment is used, it must meet or exceed the critical specifications.

**Table 3. Recommended Test Equipment**

Instrument Type	Critical Specifications	Suggested Model	Use*
Power Meter	No substitute	HP 435B	A
Digital Voltmeter	Range: 100 mV dc to 100 V dc Input Impedance: 10 MΩ Resolution: 4-digit Accuracy: ±0.05% ± 1 digit	HP 3478A	A,T
Oscilloscope;	Bandwidth: dc to 50 MHz Vertical Sensitivity: 0.2 V/div Horizontal Sensitivity: 1 ms/div	HP 54200A	A,T
10:1 Divider Probe	10 MΩ 10 pF	HP 10004D	A
Ohmmeter	Range: 1Ω to 100 kΩ Accuracy: ±5%	HP 3478A	T
dc Power Supply	Range: 0-20 Vdc Load Regulation: 0.01% + 4 mV	HP 6204B	T
*A = Adjustment, T = Troubleshooting			

---

## Installation

**Initial Inspection** Inspect the shipping container for damage. If the shipping container or packaging material is damaged, it should be kept until the contents of the shipment have been checked mechanically and electrically. If there is mechanical damage or if the instrument does not pass the performance tests, notify the nearest Hewlett-Packard office. Keep the damaged shipping materials (if any) for inspection by the carrier and a Hewlett-Packard representative.

## Storage and Shipment

### Environment

The instrument should be stored in a clean, dry environment. The following limitations apply to both storage and shipment:

Temperature	-40 to +75°C
Relative humidity	< 95%
Altitude	< 7,600 metres (25,000 feet).

### Original Packaging

Containers and materials identical to those used in factory packaging are available through Hewlett-Packard offices. If the instrument is being returned to Hewlett-Packard for servicing, attach a tag indicating the type of service required, return address, model number, and serial number. Also, mark the container FRAGILE to ensure careful handling. In any Correspondence, refer to the instrument by model number and serial number.

**Interconnections** Refer to the power meter operating and service manual for interconnecting instructions.

---

## Operation

**Environment** The operating environment for the Power Sensor should be as follows:

Temperature	0° to 55°C
Relative humidity	< 95%
Altitude	< 4,572 metres (15,000 feet).

## Operating Precautions

### Caution



If the following energy and power levels are exceeded, the power meter system may be damaged.

Maximum Average Power: 300 mW  
 Maximum Peak Power: 15W  
 Maximum Energy Per Pulse: 30W · μs

Never apply torque to the body of the Power Sensor. When making connections, turn only the knurled portion of the connecting nut.

The RF connector bead deteriorates when contacted by chlorinated hydrocarbons such as acetone, trichlorethane, carbon tetrachloride, and benzene. Clean the connector face with a cotton swab moistened in isopropyl alcohol. If the swab is too large, use a wooden toothpick wrapped in a lint free cotton cloth, moistened in isopropyl alcohol.

### Power Meter Calibrations

Power meter to Power Sensor calibration procedures differ with the power meter. Follow the calibration procedure located in your power meter operating manual.

### Operating Instructions

To operate the Power Sensor, refer to the operating instructions in Section III of the power meter operating manual. Note, under power meter calibrations above, that each power meter requires a different calibration procedure.

### Power Measurements

To correct for varying responses at different frequencies a cal factor table is included on the Power Sensors. To use the cal factor at the frequency of interest, adjust the power meter's CAL FACTOR control according to the instructions in the power meter's operating and service manual. If you are using an HP 435B or HP 436A, the minimum cal factor setting is 85% and the maximum is 100%.

If the cal factor setting for your frequency of interest is below the meter's minimum or above the meter's maximum, set the cal factor control to 100%, and divide the reading in watts units (milliwatts or microwatts) by the decimal equivalent of the cal factor. For example, if the cal factor is 75%, divide the reading by 0.75. (This will result in a larger value of power than that displayed by the meter.) If the cal factor is 104% divide the reading by 1.04. (This will result in a smaller value of power than that displayed by the meter.)

### Note



To calculate corrected dBm use the following formula:  
 Correction dB = Reading dB - (10 log<sub>10</sub>CAL Factor decimal)

The sensitivity of the Power Sensor is influenced by ambient temperature. The sensor should be recalibrated at each change in temperature to obtain the most accurate results.



**Modulation Effects**

When measuring microwave sources that are modulated at the chopper frequency (nominally 220 Hz), at the first or second harmonic or submultiples of the chopper frequency, beat notes will occur. Unless these beat notes are exactly the chopper frequency, they can usually be eliminated by averaging since the amplitudes are plus and minus the actual power. These frequencies may also be avoided by changing the modulation frequency slightly, if possible.

If you are using an HP 437B Power Meter select a manual filter setting of at least 128 averages (as displayed on power meter) to minimize beat note interference. To minimize beat note interference using an HP 438A Power Meter select a filter number of at least 7.

---

**Performance Tests**
**Standing Wave Ratio (SWR) and Reflection Coefficient (Rho) Performance Test**

This section does not establish preset SWR test procedures since there are several test methods and different equipment available for testing the SWR or reflection coefficient. Therefore, the actual accuracy of the test equipment must be accounted for when measuring against instrument specifications to determine a pass or fail condition. The test system used must not exceed the system uncertainties shown in Table 4.

For a more complete description of measurements of SWR and return loss, we recommend Application Note 183, High Frequency Swept Measurements, HP part number 5952-9200.

**Table 4. Power Sensor Reflection Coefficient**

Frequency	System Rho Uncertainty	Actual Measurement	Maximum SWR (Rho)
50 Mhz to 100 MHz	$\pm 0.010$	_____	1.15 (0.070)
100 MHz to 2 GHz	$\pm 0.010$	_____	1.10 (0.048)
2 to 12.4 GHz	$\pm 0.015$	_____	1.15 (0.070)
12.4 to 18 GHz	$\pm 0.020$	_____	1.20 (0.091)
18 to 26.5 GHz	$\pm 0.020$	_____	1.25 (0.111)
26.5 to 33 GHz	$\pm 0.020$	_____	1.40 (0.166)

## FET Balance Adjustment

The FET balance adjustment should be performed if the wires connecting J1 to the A2 printed circuit have been moved. If you have replaced A2 or moved the wires during troubleshooting you will need to perform this adjustment. You do not need to perform a FET balance adjustment after an A1 bulkhead assembly replacement if the wires between J1 and A2 have not been disturbed.

### Warning



**The following procedure exposes high voltage areas within the power meter. Use extreme care while working around these areas or personal injury could occur.**

### Equipment

Oscilloscope	HP 54200A
Power Meter	HP 435B
Multimeter	HP 3478A

The sampling gate balance is affected by the relative positions of the wires in the Power Sensor, which connect to pins G and H of connector J1. One wire is black and white; and the other is brown and white. Moving the black and white wire will adjust the switching transient amplitude (spike). Moving the brown and white will change the offset. Once positioned, care must be used not to displace these wires. To correctly position these wires, after replacement of the printed circuit board or if the wires have been moved so as to affect the sampling gate balance, perform the following procedure:

- Set the multimeter controls as follows:
 

FUNCTION	dc Voltage
RANGE	20 mV, full scale
- Set oscilloscope controls as follows:
 

SENSITIVITY	0.2 V/DIV
SWEEP	1 ms/DIV
TRIGGER	INT
DISPLAY	A
- Set the Power Meter CAL FACTOR to 100%. Set the Power Meter RANGE to 1 mW (0 dBm).
- Open the Power Sensor (see "Disassembly Procedure", steps 1 through 3). Zero and calibrate the Power Meter. Leave the opened Power Sensor connected to the Power Meter POWER REF output. Heat can affect the adjustments so handle the sensor as little as possible.
- Turn OFF the POWER REF switch on the rear panel of the Power Meter.
- Remove the HP 435B bottom panel. This will expose the circuit side of the A5 printed circuit board. On A5 you will see a long double row of soldered terminals numbered 1 to 44.
- Connect a probe from pin 40 (the number "902" is printed on the board next to pin 40) to the multimeter input.
- Lay the HP 435B on its left side and remove the right panel. This will expose the A4 assembly.

9. Connect a 1:1 probe from TP4 to channel A on the oscilloscope.
10. **Offset.** Read the multimeter and adjust the position of the brown and white wire until the reading is between  $-7.0$  mV and  $-2.0$  mV. *Helpful hint:* the relative position of the brown and white wire to C4 will adjust the offset.
11. **Switching transients.** Read the oscilloscope and adjust the position of the black and white wire until the switching transients are less than 0.8V peak to peak. *Helpful hint:* the relative position of the black and white wire to the collector of Q1 will adjust the switching transients.

You will find that positioning the wire for switching transients affects the offset. Go back and forth between the two wires, positioning and repositioning, until both adjustments are within specifications.

---

## Replaceable Parts

Table 5 is a list of replaceable parts. Figure 2 is the illustrated parts breakdown (IPB) that identifies the major assemblies and chassis parts. Figure 6 is the IPB that identifies and depicts replaceable parts within the A1 Bulkhead Assembly. The mounting locations of the components on the A2 Input Amplifier Assembly are shown in Figure 3. To order a part, quote the Hewlett-Packard part number and Check Digit (CD), specify the quantity required, and address the order to the nearest Hewlett-Packard office (listed inside cover). To order a part not listed in Table 5, give the instrument model number, instrument serial number, the description and function of the part, and the quantity of parts required.

### Note



Within the USA, it is better to order directly from the HP Parts Center in Roseville, California. Ask your nearest HP office for information and forms for the "Direct Mail Order System." Also your nearest HP office can supply toll free telephone numbers for ordering parts and supplies.

---

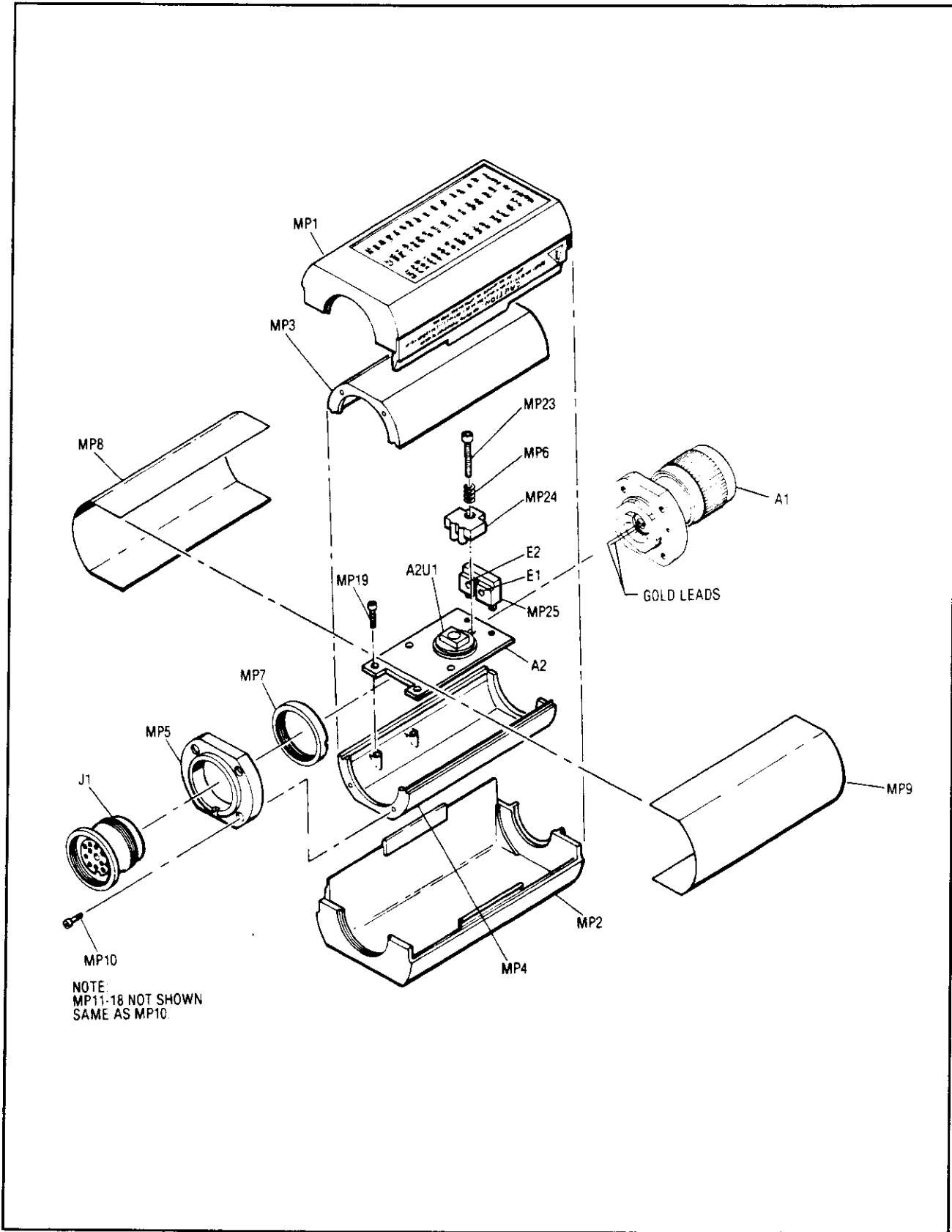

Figure 2. Illustrated Parts Breakdown

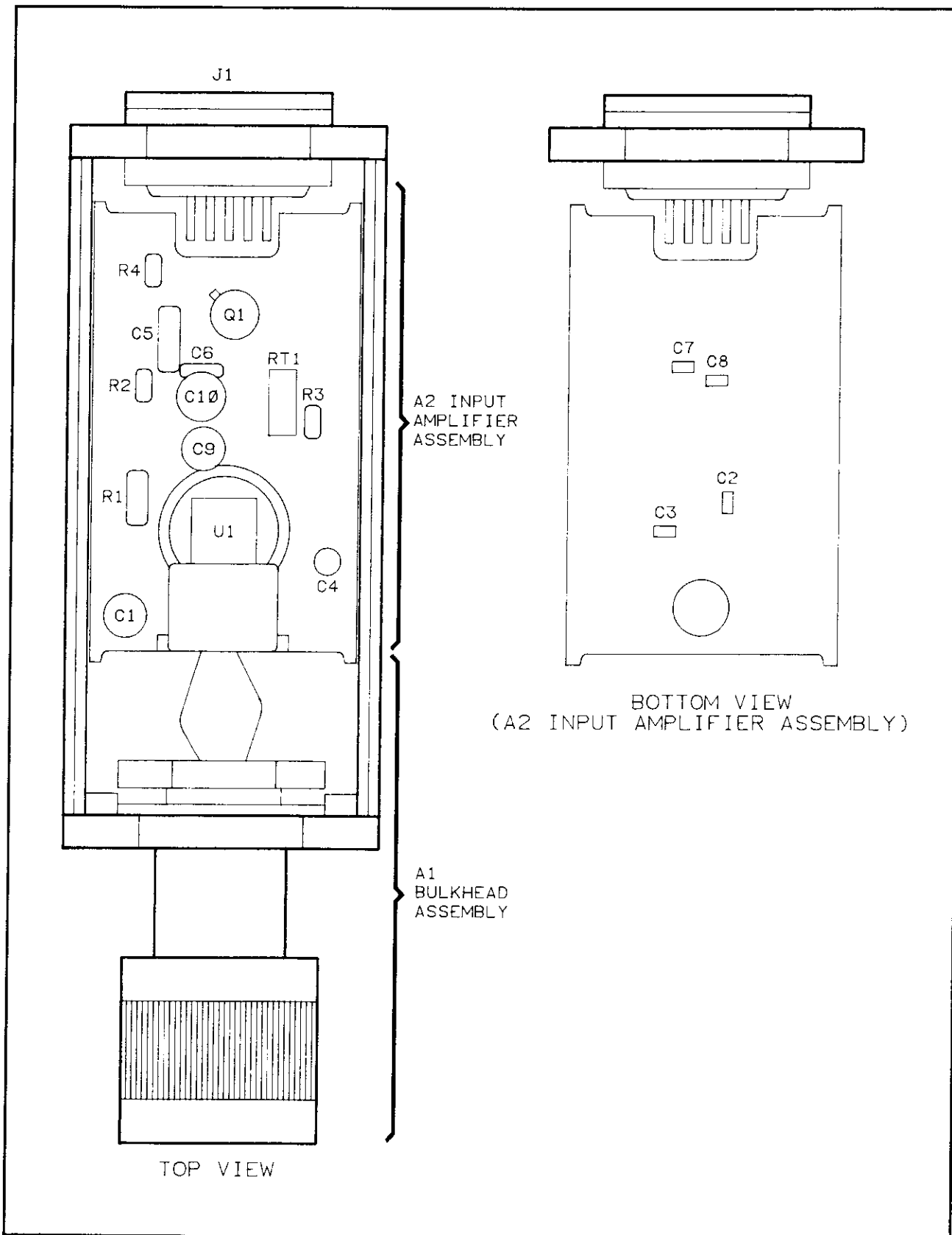

Figure 3. Component and Assembly Locations

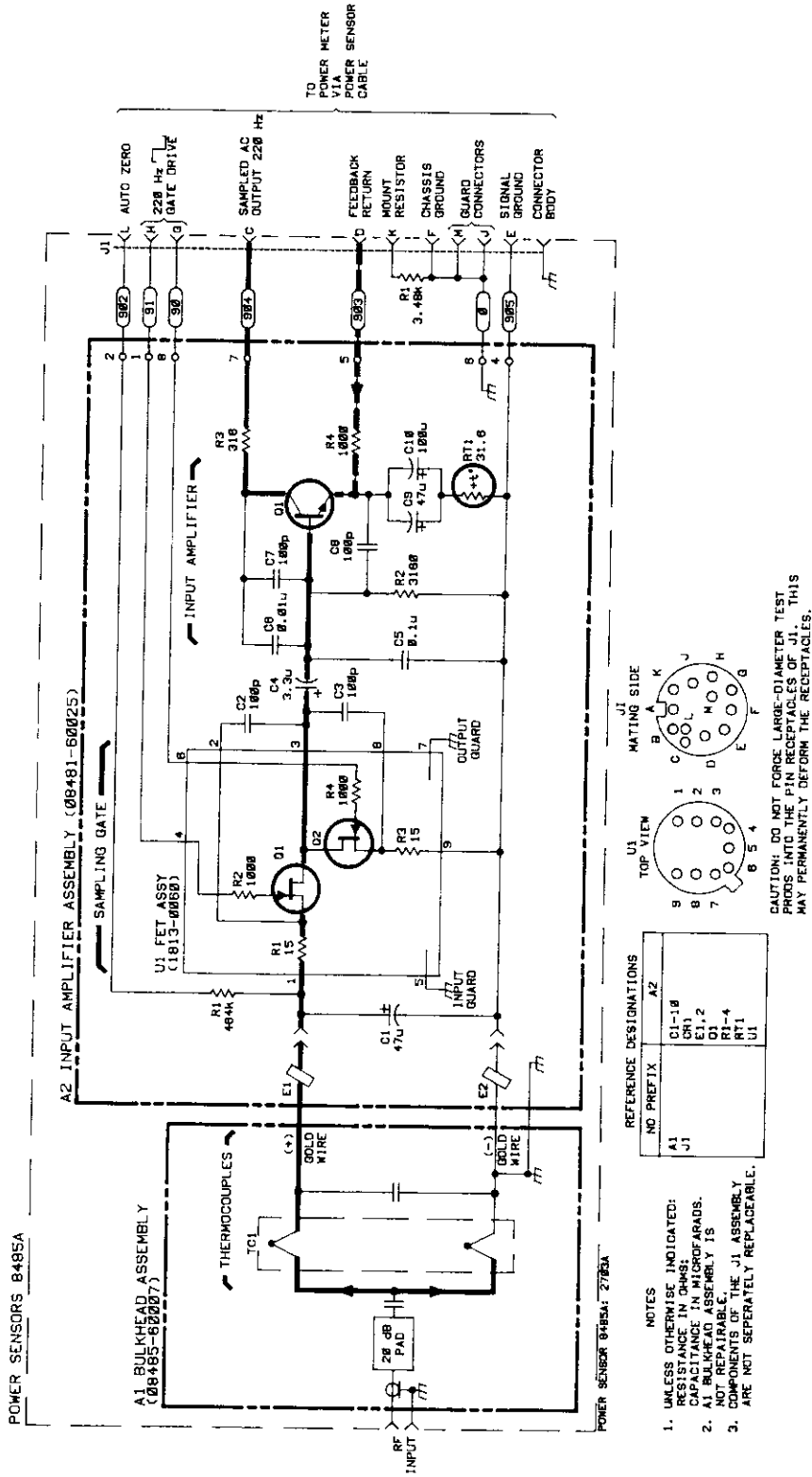

Figure 4. Schematic Diagram

Table 5. Replaceable Parts

Reference Designation	HP Part Number	C D	Qty	Description	Mfr Code	Mfr Part Number
A1	08485-60007	0	1	BULKHEAD ASSEMBLY	28480	08485-60007
A1MP1	08486-20007	7	1	CAP NUT	28480	08486-20007
A1MP2	08486-40001	3	1	FEED THRU INSUL.	28480	08486-40001
A1MP3	08485-60009	2	1	CARTRIDGE ASSY	28480	08485-60009
A1MP4	08485-20024	7	1	CUP WASHER	28480	08485-20024
	5021-7094	7	1	ALTERNATE CUP WASHER	28480	5021-7094
A1MP5	5021-9206	7	1	SPACER BELLOUS	28480	5021-9206
A1MP6	5021-7091	4	1	COAX OUTER INTERNAL	28480	5021-7091
A1MP7	08485-60010	5	1	BELLOUS ASSEMBLY	28480	08485-60010
A1MP8				NOT ASSIGNED		
A1MP9	5021-7093	6	1	CENTER COND. INTL.	28480	5021-7093
A1MP10	5040-6958	0	1	MOLDED CENTER COND.	28480	5040-6958
A1MP11	00281-20046	1	1	OUT SHIM 0.038 MM	28480	00281-20046
A1MP12	5021-7092	5	1	COAX OUTER EXTERNAL	28480	5021-7092
A1MP13	08485-20011	2	1	SENSOR HOUSING	28480	08485-20011
A1MP14	1250-0016	0	1	COMPONENT-RF CONNECTOR SERIES N; .75 IN	24931	R100-1
A1MP15	08485-20005	4	1	NUT RF CONN	28480	08485-20005
A1MP16	6040-0664	4	1	LUBRICANT	71984	MOLYKOTE 44 MEDIUM CONSISTENC
A2	08481-60025	8	1	POWER SENSOR BOARD ASSEMBLY	28480	08481-60025
A2C1	0180-2515	8	2	CAP-FXD 47uF 6 V TA	12344	T355F476M006AS
A2C2	0160-0565	7	4	CAP-FXD 1000pF 100 V	00843	0805C101K3P
A2C3	0160-0565	7		CAP-FXD 1000pF 100 V	00843	0805C101K3P
A2C4	0180-0594	9	1	CAP-FXD 3.3uF 15 V TA	12344	T350A335M16AS
A2C5	0160-3094	8	1	CAP-FXD 0.1uF 100 V	06383	FD22X5R2A104K
A2C6	0160-3879	7	1	CAP-FXD 0.01uF 100 V	09969	RPE121-105X7R103M100V
A2C7	0160-0565	7		CAP-FXD 1000pF 100 V	00843	0805C101K3P
A2C8	0160-0565	7		CAP-FXD 1000pF 100 V	00843	0805C101K3P
A2C9	0180-2515	8		CAP-FXD 47uF 6 V TA	12344	T355F476M006AS
A2C10	0180-2545	4	1	CAP-FXD 100uF 4 V TA	01766	202L6301-107-M6-552
A2Q1	1854-0610	0	1	TRANSISTOR NPN SI TO-46 FT=800MHZ	28480	1854-0610
A2R1	0698-3260	9	1	RESISTOR 464K +-1% .125W TF TC=0+-100	12498	CT4
A2R2	0698-7248	1	1	RESISTOR 3.16K +-1% .05W TF TC=0+-100	12498	C3-1/8-T0-3161-F
A2R3	0698-7224	3	1	RESISTOR 316 +-1% .05W TF TC=0+-100	12498	C3-1/8-T0-316R-F
A2R4	0698-7236	7	1	RESISTOR 1K +-1% .05W TF TC=0+-100	12498	C3-1/8-T0-1001-F
A2RT1	0811-3210	1	1	RESISTOR 31.6 +-5% .05W PN TC=+5040+-250	01686	R342
A2U1	1813-0060	8	1	IC MISC TO-8 PKG	28480	1813-0060
				A2 MISCELLANEOUS PARTS		
	0590-1040	1	1	THREADED INSERT-NUT 0-80 .06-IN-LG SST	46384	YC3-1505
	5040-6938	6	1	SPACER	28480	5040-6938
				CHASSIS PARTS		
Z1	08481-60024	7	1	CONNECTOR ASSEMBLY-12 PIN	28480	08481-60024
MP1	5040-6998	8	2	SHELL-PLASTIC	28480	5040-6998
MP2	5040-6998	8		SHELL-PLASTIC	28480	5040-6998
MP3	08481-20011	8	2	CHASSIS	28480	08481-20011
MP4	08481-20011	8		CHASSIS	28480	08481-20011
MP5	08481-20008	3	1	END BELL	28480	08481-20008
MP6	1460-1978	9	1	SPRING-CPRSN .088-IN-OD .188-IN-DA-LG	84830	C1-008B-2-SS
MP7	1251-3363	8	1	NUT-AUDIO CONN	05876	91-T-1335-6-9
MP8	08481-00002	5	2	SHIELD	28480	08481-00002
MP9	08481-00002	5		SHIELD	28480	08481-00002
MP10	3030-0952	9	4	SCREW-SET 1/4-20 2-IN-LG CUP-PT STL	00000	ORDER BY DESCRIPTION
MP11	3030-0952	9		SCREW-SET 1/4-20 2-IN-LG CUP-PT STL	00000	ORDER BY DESCRIPTION
MP12	3030-0952	9		SCREW-SET 1/4-20 2-IN-LG CUP-PT STL	00000	ORDER BY DESCRIPTION
MP13	3030-0952	9		SCREW-SET 1/4-20 2-IN-LG CUP-PT STL	00000	ORDER BY DESCRIPTION
MP14	3030-0954	1	9	SCREW-SKT HD CAP 0-80 .188-IN-LG SST-304	00000	ORDER BY DESCRIPTION
MP15	3030-0954	1		SCREW-SKT HD CAP 0-80 .188-IN-LG SST-304	00000	ORDER BY DESCRIPTION

Table 5. Replaceable Parts (Cont'd)

Reference Designation	HP Part Number	C D	Qty	Description	Mfr Code	Mfr Part Number
MP16	3030-0954	1		SCREW-SKT HD CAP 0-80 .188-IN-LG SST-304	00000	ORDER BY DESCRIPTION
MP17	3030-0954	1		SCREW-SKT HD CAP 0-80 .188-IN-LG SST-304	00000	ORDER BY DESCRIPTION
MP18	3030-0954	1		SCREW-SKT HD CAP 0-80 .188-IN-LG SST-304	00000	ORDER BY DESCRIPTION
MP19	3030-0422	1		SCREW-SKT HD CAP 0-80 .188-IN-LG SST-304	00000	ORDER BY DESCRIPTION
MP20	3030-0422	1		SCREW-SKT HD CAP 0-80 .188-IN-LG SST-304	00000	ORDER BY DESCRIPTION
MP21	3030-0422	1		SCREW-SKT HD CAP 0-80 .188-IN-LG SST-304	00000	ORDER BY DESCRIPTION
MP22	3030-0422	1		SCREW-SKT HD CAP 0-80 .188-IN-LG SST-304	00000	ORDER BY DESCRIPTION
MP23	3030-0436	4	1	SCREW-SKT HD CAP 0-80 .5-IN-LG SST-300	00000	ORDER BY DESCRIPTION
MP24	5040-6939	7	1	CLAMP	28480	5040-6939
MP25	5040-6940	0	1	BLOCK	28480	5040-6940
MP26	08485-80002	7	1	LABEL-IDENTIFICATION	28480	08485-80002
MP27	<del>08486-80005</del>	1	1	LABEL INFORMATION (SIDE)	28480	7120-8714
MP28	08485-60005	8	1	ADAPTER-COAX N-TYPE M 3.5 MM	28480	08485-60005
MP29	7121-2422	9	1	LABEL-CAUTION	28480	7121-2422
MP30	08481-80005			MYLAR TAPE		
MP31	08486-80005			LABEL-INFORMATION		
MP32	08486-80006			LABEL-BLANK		

Table 6. Code list of Manufacturers

Mfr Code	Manufacturer Name	Address	Zip Code
00000	ANY SATISFACTORY SUPPLIER		
00843	HOFFMAN ENG CO DIV OF FED CARTRIDGE		
01686	RCL ELECTRONICS INC	ANOKA MN	55303
01766	INTL CRYSTAL MFG CO INC	NORTHBROOK IL US	60062
05876	U S POLYMERIC INC	OKLAHOMA CITY OK	73102
06383	PANDJIT CORP	STAMFORD CT	06904
09969	DALE ELECTRONICS INC	TINLEY PARK IL US	60477
12344	TALLY CORP	YANKTON SD US	57078
12498	CRYSTALONICS, DIV TELEDYNE	KENT WA	98031
24931	SPECIALTY CONNECTOR CO	CAMBRIDGE MA	02140
28480	HEWLETT-PACKARD CO CORPORATE HQ	FRANKLIN IN US	46131
46384	PENN ENGINEERING & MFG CORP	PALO ALTO CA	94304
71984	DOW CORNING CORP	DOYLESTOWN PA US	18901
84830	LEE SPRING CO	MIDLAND MI	48641
		BROOKLYN NY US	11219



---

## Service

Service instructions consist of principles of operation, troubleshooting, and repairs. Test equipment which meets or exceeds the critical specifications in Table 3 may be used in place of the recommended instruments for troubleshooting the Power Sensor.

### Note



Check your warranty. Opening the Power Sensor will void warranty.

---

## Principles of Operation

For the following discussion, refer to Figure 4 Schematic Diagram and Figure 5 Operational Amplifier. The operational amplifier is made up of the Power Sensor input amplifier, A2Q1, and the first amplifier stage in the power meter.

For additional information on thermocouple sensors, refer to HP Application Note 64-1, Fundamentals of RF and Microwave Power Measurements.

The A1 Bulkhead Assembly provides a 50 ohm load to the rf signal applied at the RF INPUT. The rf signal is coupled through a dc blocking capacitor and absorbed by the thermocouples which generate a dc voltage proportional to the rf input power. The dc voltage is routed from the thermocouples to the input amplifier on gold wires to reduce undesired thermocouple effects. The gold wires pass through ferrite beads A2E1 and A2E2 which are located in the black plastic block. (See Figure 2.) The ferrite beads increase the self inductance of the gold wires causing this portion of the wires to provide the properties of an rf choke. The result is to minimize rf feedthrough to the A2 Input Amplifier Assembly.

The dc output from the bulkhead assembly is applied to the two field effect transistors (FETs) in A2U1. These transistors function as a sampling gate or chopper. The sampling rate is controlled by a 220 Hz square wave supplied by the power meter. The amplitude of the sampling gate output (at pin 3 of A2U1) is a 220 Hz square wave proportional to the power input. The sampled 220 Hz ac output is applied to the input amplifier A2Q1 which is the input stage for an operational amplifier (Figure 5). The ac gain of the operational amplifier is approximately 700.

A dc feedback voltage from the power meter Auto Zero circuit is coupled to the input of FET A2U1Q1 to set the zero level. The voltage is developed across the voltage divider consisting of A2R1 and the series resistance of the thermocouple A1TC1.

When the Power Sensor is used with an HP Power Meter, the short to ground at J1-K (Mount Resistor) causes the power meter to automatically select the proper measurement range of  $-30$  to  $+20$  dBm.

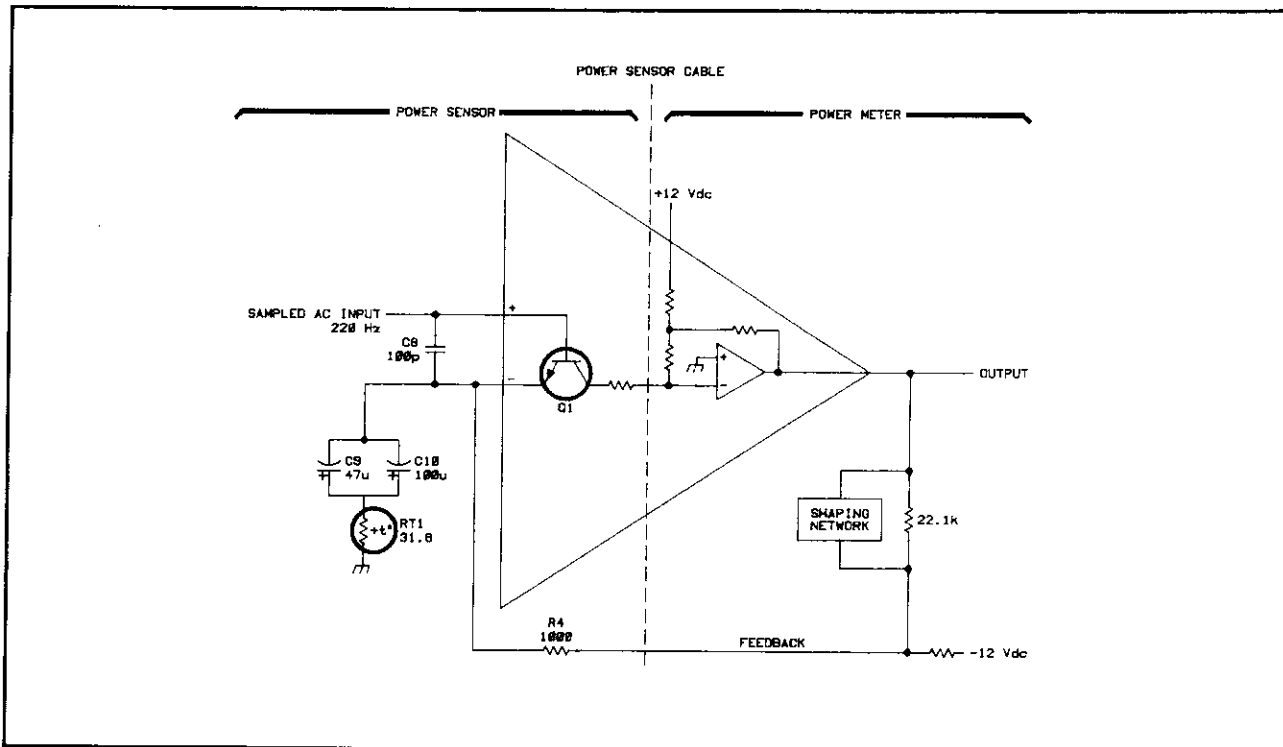

Figure 5. Operational Amplifier

**Troubleshooting**

The troubleshooting information is intended to first isolate the Power Sensor or power meter as the defective component. When the Power Sensor is isolated, troubleshooting information is intended to identify A1 Bulkhead Assembly or A2 Input Amplifier Assembly as the defective component.

Before you open the Power Sensor to continue with the troubleshooting procedures, try the substitution method of elimination. Use another Hewlett-Packard power meter, known to be in good operating condition, with the suspected power sensor and cable. If the same problem occurs with the “known good” power meter, substitute a “known good” power sensor cable.

Troubleshooting should be performed with the Power Sensor opened, the printed circuit board exposed. See “Disassembly” close to the end of this manual.

When a failed assembly has been identified, go to “Repair” directly following “Troubleshooting”.

**Caution**



Excessive power will damage the thermocouples.

**Power Meter**

To ensure the power meter is providing the correct 220 Hz signal, check the following levels of the square wave with an oscilloscope.

- At the white-black wire:  $-0.05 \pm 0.05$  Vdc (top of square wave).
- At the white-brown wire:  $-9.0$  Vdc (bottom of square wave).

If the levels are correct the Power Sensor is at fault. Continue troubleshooting A1 Bulkhead Assembly. If the levels are incorrect, the power meter is at fault. Refer to the power meter service manual for troubleshooting information.

### Power Sensor

The most common cause of Power Sensor failure is the application of power levels beyond the specified tolerance. The second most common cause of failure is applying torque to the body of the Power Sensor. Either of these common causes will damage the bulkhead cartridge unit (which holds the thermocouples). If this happens, the fault will cause a short or an open between the two gold wires.

### Caution



Be extremely careful when measuring across the gold wires. They are delicate and can be damaged easily.

1. Disconnect all cables from the power sensor.
2. Remove the clamp holding the two gold wires.
3. Resistance measured between the two gold wires from the A1 Bulkhead Assembly should be  $200 \pm 10$  ohms. If you cannot obtain the proper resistance the A1 Bulkhead Assembly is defective. If the resistance is correct continue to the next step.
4. Attach the bulkhead (via the adapter) to the 1 mW 50 MHz reference power of your power meter. When the rf input power is 1 mW, the bulkhead assembly generates  $+0.17 \pm 0.03$  mV across the two gold wires. If this voltage is correct, the A2 Assembly is at fault. If the voltage is incorrect, the bulkhead assembly is defective.

### A2 Input Amplifier Assembly

It is rare for the A2 Assembly to fail. Eliminate the power meter, the bulkhead assembly and the connectors before suspecting the A2 Assembly.

In most cases, the operational amplifier (made up of A2Q1 and the first amplifier of the power meter, Figure 5) is operating correctly if the dc voltage on the metal cover of A2Q1 (collector) is  $-70 \pm 30$  mV dc. Refer to the schematic to troubleshoot further.

**Repair** Power Sensor repair consists of A1 Bulkhead replacement or repair and A2 Input Amplifier replacement.

### Repair Strategy

**Bulkhead.** You can choose to either replace your A1 Bulkhead Assembly, or repair it yourself. We recommend replacing the A1 Bulkhead with a new or restored bulkhead over attempting to rebuild it. A restored Bulkhead is rebuilt and calibrated at the factory. It comes with a calibration report and new calibration sticker for your sensor.

If you decide to repair the bulkhead yourself, you should have an HP 11760S E01 Automated Power Sensor Calibration System and, when repairs are finished, the appropriate SWR test setup. (See Performance Tests for system specifications.)

### Note



Although at the start, rebuilding the bulkhead requires considerable patience, the skills to do the job can be quickly learned. If you repair power sensors often and have the proper calibration systems, bulkhead repair can be more economical than replacement.

**A2 Input Amplifier Assembly Printed Circuit.** If the A2 Input Amplifier Assembly is at fault, replace it. Replacing the A2 Assembly is usually less costly than the time it takes to troubleshoot and replace faulty components. For those who wish to troubleshoot, use Figure 4 Power Sensor Schematic Diagram.

### Bulkhead Replacement

Read repair strategy, above. Bulkhead replacement differs from repair in that no special tools or skills are required other than those needed to do the FET balance adjustment.

### Procedure

1. Order your new or restored A1 Bulkhead Assembly from Table 5 Replaceable Parts.
2. Follow the disassembly and reassembly procedure for bulkhead removal and replacement located near the end of this manual.
3. Place the new calibration sticker on the power sensor cover.

### Bulkhead Repair

Read the repair strategy, above. The repair procedure has two parts: cartridge replacement and a more complex bulkhead rebuild procedure. Inspect the center conductor and outer conductor with a magnifying glass. If you have any burrs or scratches visible on the connecting surfaces you should rebuild (or replace) the bulkhead. Both repair procedures require considerable manual dexterity. *Do not attempt repair without the following equipment.*

**Equipment:**

HP 11760S E01	Power Sensor Calibration System
HP 11752D	3.5 mm Connector Gage
SWR Test Set	See Performance Test for specifications.

**Rebuilding the Bulkhead.** When you rebuild the bulkhead you will replace the center conductor (pin), outer conductor (shoulder), bellows assembly, and cartridge unit.

**Note**

When an inexperienced person was used to test this procedure, replacing the bellows A1MP7, was the most difficult. Tweezers were used. One bellows was nearly lost and one destroyed by squeezing too hard. With a little experience the procedure becomes simple. If this is your first repair, save your old bellows and order a new one for a spare.

1. Refer to the parts list Table 5 and Figure 6. Order the internal bulkhead parts A1MP3 through A1MP12.
2. Set up the necessary equipment for your SWR test. See Performance Test in this manual for system specifications.
3. Remove the bulkhead assembly from the Power Sensor. See the disassembly procedure near the end of this manual.
4. Using a 5/8 in (16mm) wrench remove the cap nut and disassemble the bulkhead. Save the bellows A1MP7, the cap nut A1MP1, the feed through insulator A1MP2, and the sensor housing A1MP13, 14 and 15. Discard the old parts, A1MP3 through A1MP6 and A1MP9 through A1MP12.
5. Replace A1MP12, the outer conductor, and washer A1MP11. Screw together A1MP9 and A1MP10 until finger tight. Put it into place. Replace A1MP6, the internal outer conductor. Replace A1MP4, the cup washer, cup side down, flat side facing the cartridge. Now replace the flat washer A1MP5. See the note after step 15 about improving SWR.
6. Look at the bellows under a magnifying glass. One flat end and one narrow end is held apart by fanfolded metal. It is very important that the narrow end seats into the top of A1MP9. If you are using tweezers, lay the bellows horizontally so that the narrow end is resting at the mouth of A1MP9 and the flat end is resting on the lip of A1MP6. Now lever the bellows into place until the narrow end is seated into A1MP9.

*Helpful hints:* One method of manipulating the bellows is to use a clear plastic tube with an inner diameter smaller than the bellows. Use the tube like a straw, and suck the bellows to the tip of the tube. Put the narrow end of the bellows in place and release the vacuum.

Continue with Step 10.

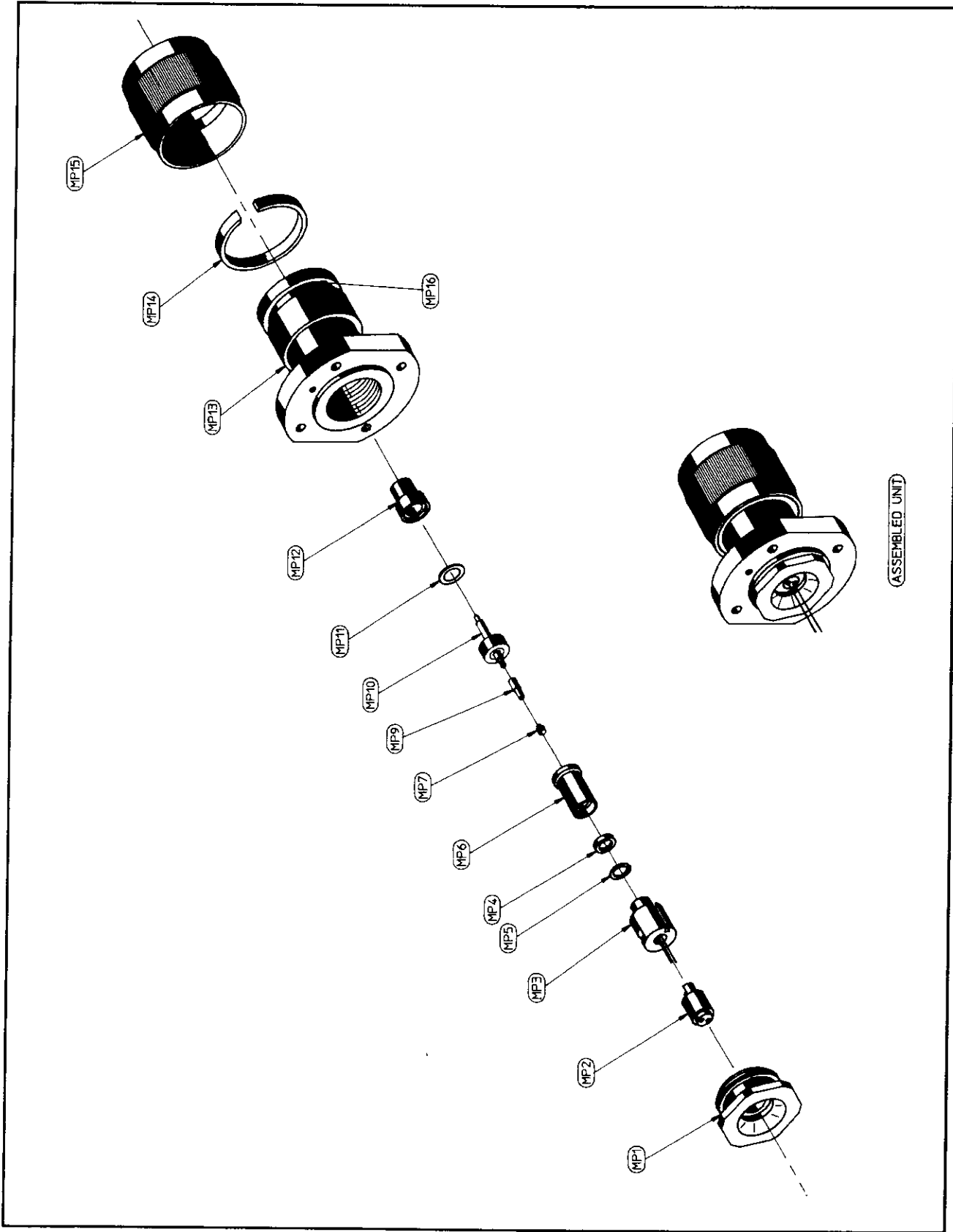

Figure 6. A1 Bulkhead Illustrated Parts Breakdown

**Cartridge Replacement.** If you do not need to replace the inner and outer conductors of your Power Sensor, start here. The procedure assumes the bulkhead assembly is removed from the Power Sensor.

7. Order one cartridge replacement A1MP3.
8. Place the bulkhead on its face, connector side down with the gold wires pointing up. Using a 5/8 in (16 mm) open end wrench, carefully remove the cap nut A1MP1.
9. So as not to disturb the bellows assembly beneath, carefully grasp the two gold wires and vertically lift the cartridge unit out of the bulkhead.
10. Slide the old feed through insulator A1MP2 over the gold wires onto the new cartridge unit. The long piece of the insulator goes under the substrate in the cartridge unit.
11. Look into the bulkhead assembly to make sure nothing was disturbed. If everything is in place, hold the new cartridge unit by the two gold wires and lower it onto the bellows.
12. Replace the cap screw. When the screw is about half a turn from being finger tight, press lightly on the insulator with the point of a pencil. A slight springlike action indicates the cartridge is properly seated.

**Caution**

---

Damage can occur to both the cartridge and bellows assemblies if they are not properly mated. If no springlike action (or “give”) is present remove the cartridge assembly and make sure the bellows assembly A1MP7 is in place on the center conductor.

---

13. Tighten the cap nut to finger tight then torque the cap nut to to 25 in-lbs (282.5 N-cm).
14. If you are only replacing the cartridge unit, this step is unnecessary. Use a 3.5 mm connector gage (HP 11752D) to verify pin and shoulder depth. Add or remove shim A1MP11 as necessary.
15. Test for SWR. If SWR is not acceptable, read the following note.

**Note**

---

The above procedure is used at the factory and consistently yields the best SWR results. If you consider it necessary to try to improve the SWR of your unit you can try the following.

- a. Turn A1MP4 cupside up, so that the cup side will face the cartridge unit.
  - b. Use the alternate cup washer, 5021-7094. Try using it cupside up and cupside down.
  - c. Remove A1MP5. Or place it under A1MP4.
  - d. Remember to test SWR every time you change the assembly.
-

16. Finish reassembly and calibrate the repaired power sensor with your HP 11760S Automated Power Sensor Calibration System.

### **A2 Input Amplifier Assembly**

Repair is not recommended for the A2 Input Amplifier Assembly. If you have determined A2 is faulty, replace it. Order your replacement assembly from Table 5 Replaceable Parts and follow the disassembly and reassembly procedures at the end of this manual.

**Soldering.** To replace the A2 printed circuit assembly, you will have to perform some soldering to remove and replace the wires from Connector J1. Remember the Power Sensor is a highly sensitive device. As such, it is affected by very small temperature differences between its components. After doing any soldering in the unit, wait several hours for the unit to reach thermal equilibrium before using or testing it.

1. Use a temperature controlled 600°F (311°C) with a zero crossover tip.
2. Use a low temperature RMA flux SN 62 solder.
3. Do not attempt to remove flux residue from around solder joints. We have found that using a cleaning solution spreads the flux in a thin sticky layer over the entire assembly.

### **Connector Cleaning**

Keeping in mind its flammable nature, a solution of pure isopropyl or ethyl alcohol can be used to clean connectors.

### **Caution**



---

The RF connector bead deteriorates when contacted by any chlorinated or aromatic hydrocarbon such as acetone, trichlorethane, carbon tetrachloride, and benzene.

Do not attempt to clean connectors with anything metallic such as pins or paper clips.

---

Clean the connector face by first using a blast of compressed air. If the compressed air fails to remove contaminants use a cotton swab dipped in isopropyl or ethyl alcohol. If the swab is too big, use a round wooden toothpick wrapped in a lint free cloth dipped in isopropyl or ethyl alcohol.



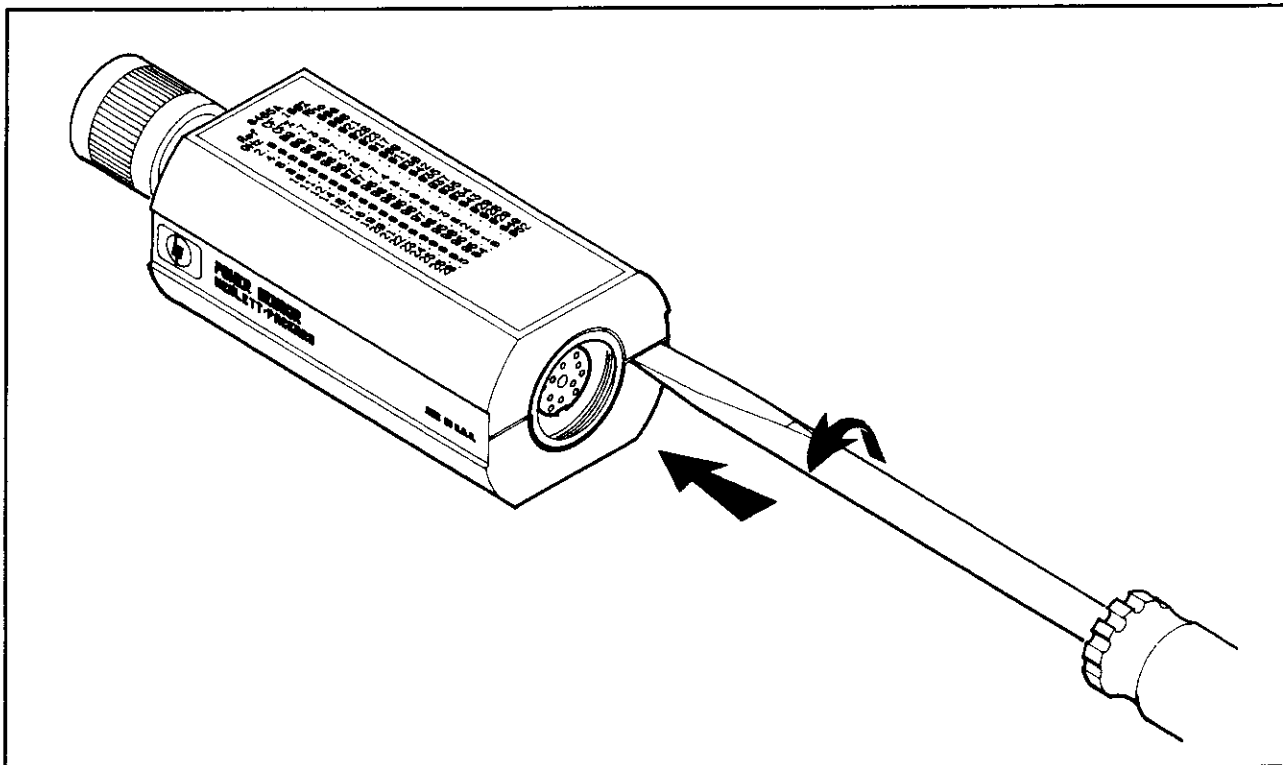

Figure 7. Removing the Power Sensor's Cover

## Disassembly Procedure

Disassemble the Power Sensor by performing the following steps:

### Caution



Disassembly must be performed in sequence described below, otherwise damage may be caused to the two gold wires between the bulkhead assembly and the input amplifier assembly. If these wires are damaged, the A1 Bulkhead Assembly must be repaired or returned to the factory for repair.

### Note



Every Power Sensor has an individually prepared graph on the housing. If more than one power sensor is disassembled at a time, be sure to mate the correct Power Sensor and housing when reassembling.

1. Insert the blade of a large screwdriver between the two-piece plastic shell at the rear of the Power Sensor. Gently pry the sections apart. (See Figure 7.)
2. Proceed to the other side of the connector and again pry the cover sections apart. Remove the shells and magnetic shields.

3. Position the Power Sensor as shown in Figure 8 (top). The small hole 5 should be on the left side of the RF input connector. Remove the allen cap screws 1, 2, 10, and 13. Loosen 11 and 12. Remove the upper chassis from the Power Sensor.
4. Remove the spring clamp cap screw 7 to free the gold leads which come from the Bulkhead Assembly.
5. Remove cap screws 3, 4, and 5.
6. Slide the Bulkhead Assembly straight out from the chassis.
7. Remove cap screws 8, 9, 11, 12, 14, and 15.
8. Lift the A2 Input Amplifier and J1 connector out of the chassis.

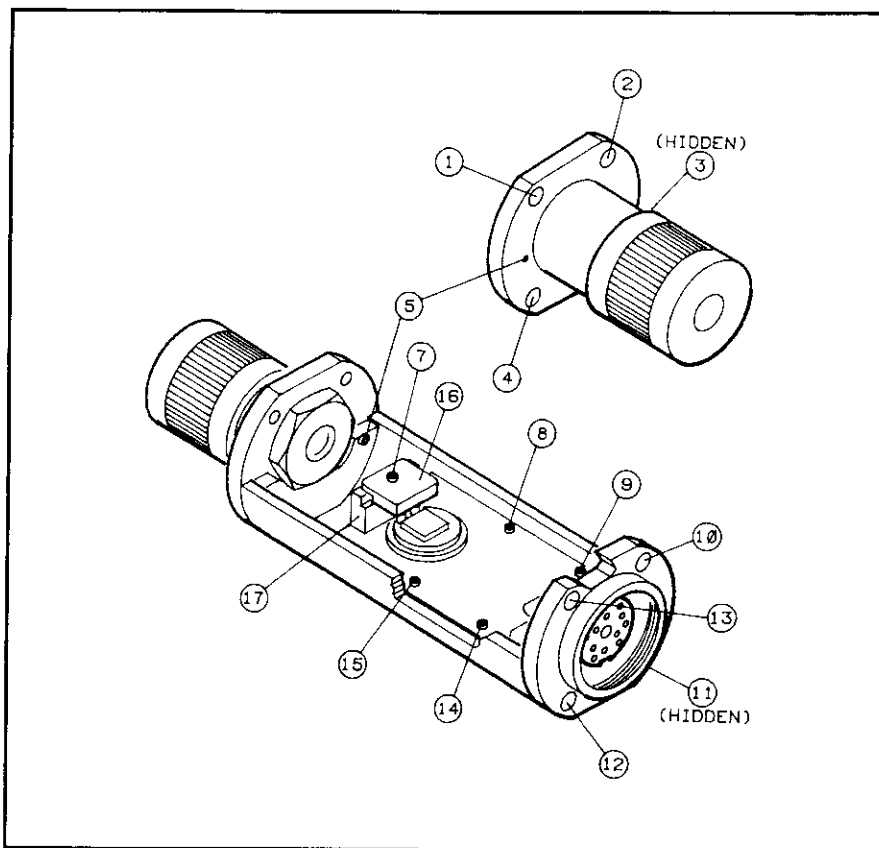

Figure 8. Power Sensor Hardware Locations

---

## Reassembly Procedures

**Caution**

---

The gold wires connecting the A1 Bulkhead Assembly and the A2 Input Amplifier Assembly are extremely delicate and may be easily broken. Be careful when working around them.

---

1. Set the printed circuit board and connector into place as shown in Figure 8, bottom view.
2. Insert cap screws **8, 9, 11, 12, 14,** and **15** but do not tighten.
3. Center the circuit board so there is equal air gap between each side and the chassis. Tighten **8, 9, 14,** and **15**.
4. With small hole **5** to the left, carefully insert the gold leads on A1 bulkhead assembly through the holes in the black plastic guide on A2 input amplifier.
5. Insert screw **3, 4,** and **5**. Tighten only screw **5**.
6. Using tweezers, position the ends of the gold wires over the electrical pads.

**Caution**

---

DO NOT tighten clamp screw **6** excessively or the FET circuit may be broken.

---

7. Place and hold plastic clamp **16** over the gold wires. As you tighten the clamp screw, watch the compression spring. Tighten the clamp screw **7** only until the spring coils touch. Any further tightening could damage the FET circuit.
8. Place the upper chassis in position and insert cap screws **1, 2, 10,** and **13**.
9. Tighten **1, 2, 3,** and **4**.
10. Tighten **10, 11, 12,** and **13**.
11. Place the plastic shells, magnetic shields, and the chassis together as shown in figure 1. Snap the plastic shells together.

## Backdating

This section contains information for adapting this manual to instruments for which the content does not directly apply.

### How to use this section.

If the serial prefix of your HP 8485A is 2915A or below, this section applies to you. Find the serial prefix that applies to your instrument and make the changes described below.

#### 2915A

Changes were made to the capacitors in the cartridge unit inside the bulkhead assembly. No manual change is necessary.

#### 2703A

1. The color of the plastic shells changed. The direct preferred replacement is listed in Table 5 Replaceable Parts.
2. The appearance of the ID labels changed. The direct preferred replacement are listed in Table 5 Replaceable Parts.
3. The Bulkhead assembly part number changed. The direct preferred replacement is listed in Table 5 Replaceable Parts.

#### 2632A

1. The changes listed for 2703A apply to this serial prefix.
2. Replace Figure 2 Component and Assembly Locations with the Figure 3 in this section.

#### 2347A

1. The changes listed for 2632A and 2703A apply to this serial prefix.
2. The appearance of the labels changed. The preferred replacements are listed in the parts list.
3. Screws MP14-MP22 changed. The preferred replacements are listed in the parts list.

#### 2238A

1. Changes listed for 2347A, 2632A, and 2703A apply to this serial prefix.
2. In Power Sensor with this prefix number pin A was added to J1. Pin A was connected to the junctions of F, M and J. When servicing Power Sensor with this prefix we recommend removing this connection, isolating pin A. See P/O Figure 4, this section.
3. The part number for J1 changed. The preferred direct replacement is listed in the parts list

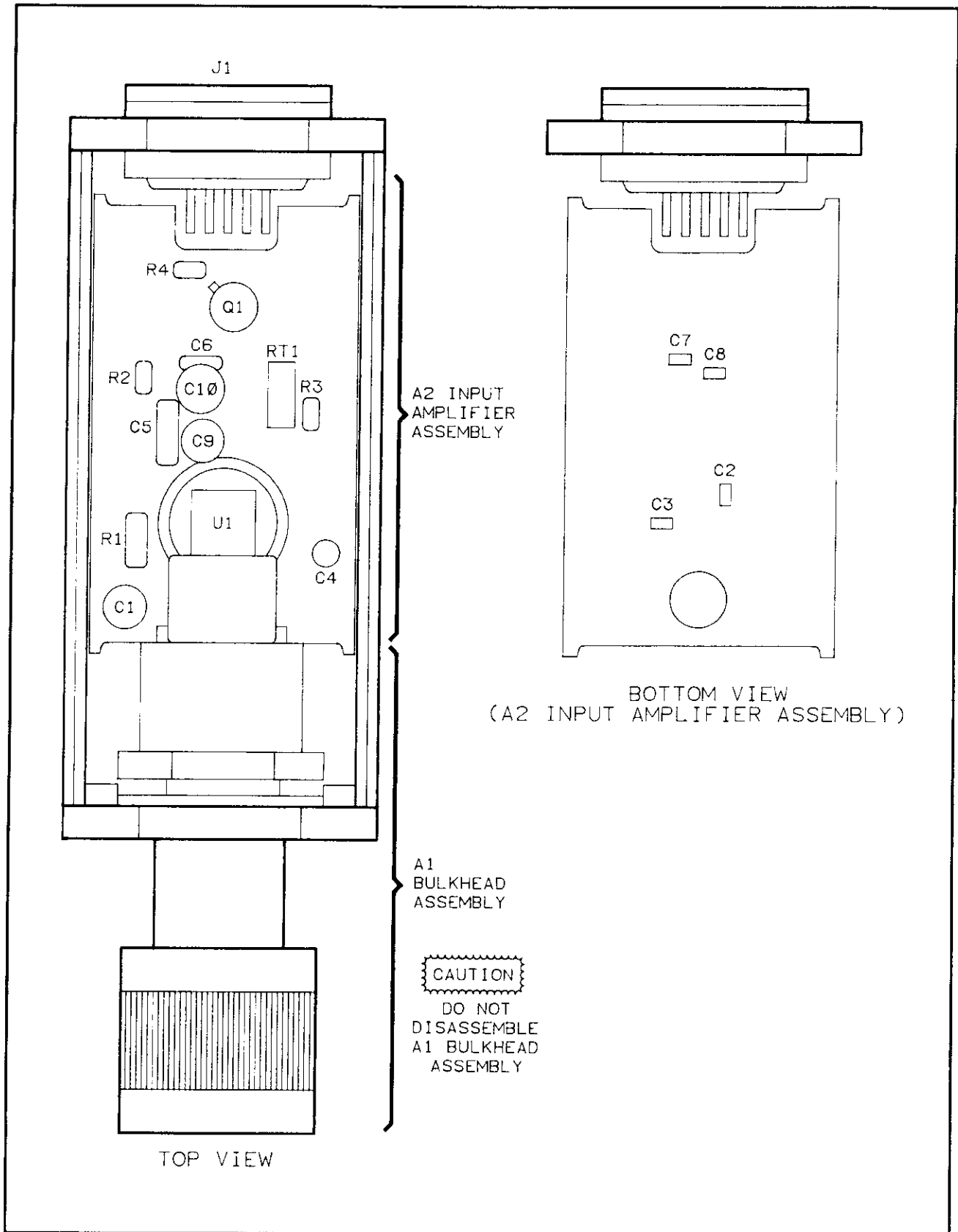
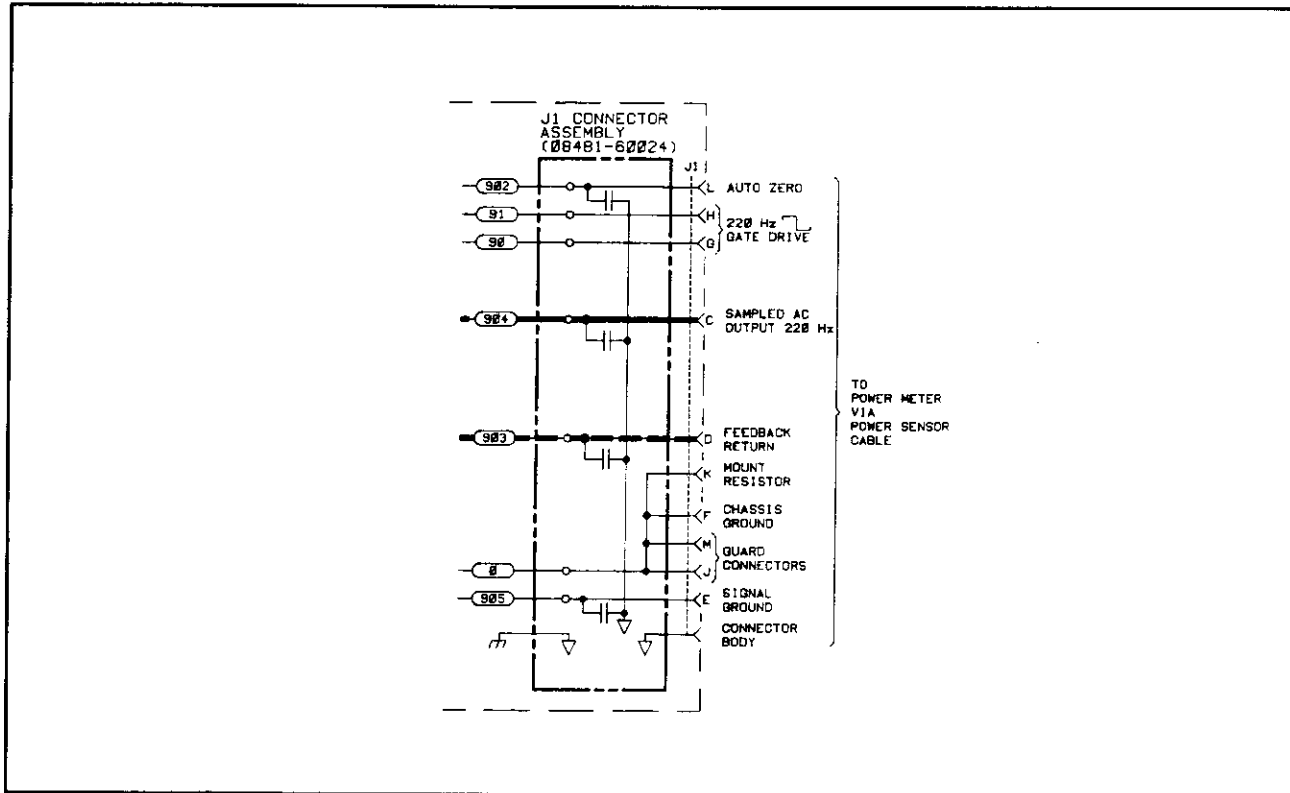

Figure 3. Component and Assembly Locations (1933A through 2632A)

1933A

1. With the exception of the addition of pin A to J1, all the changes listed for 2238A, 2347A, 2632A and 2703A apply to instruments with these prefixes.
2. Four capacitors were added to connector J1. The partial schematic of Figure 2, showing their placement, is in this section. When servicing Power Sensor with these prefixes, we recommend removing these capacitors.



P/O Figure 4. Schematic Diagram (2238A)

## REGIONAL SALES AND SUPPORT OFFICES

For information relating to Sales or Support of Hewlett-Packard products, first contact your local Hewlett-Packard office listed in the white pages of your telephone directory. If none is listed locally, contact Hewlett-Packard at one of the offices listed below to obtain the address or phone number of the Sales or Support office nearest you.

The format for telephone numbers is listed as: (country code/area code or city code) local number. For example, at European Operations HQ, the main site number is listed as: (41/22)780.8111; 41 is the country code, 22 is the city code, and 780.8111 is the local number.

### EUROPEAN MULTICOUNTRY (Scandinavia, Middle East, Africa, Eastern Europe)

Hewlett-Packard S.A.  
150, route du Nant-d'Avril  
P.O. Box 1217 Meyrin  
2/Geneva  
Switzerland  
Tel: (41/22)780.8111  
Fax: (41/22)780.8609

### FRANCE

Hewlett-Packard France  
Parc d'Activite du Bois Briard  
2, avenue du Lac  
91040 Evry Ce'dex  
France  
Tel: (33/1)69 91 80 00  
Fax: (33/1)69 91 84 32

### GERMANY

Hewlett-Packard GmbH  
Herrnberger Strasse 130  
D-7030 Boblingen  
West Germany  
Tel: (49/7031)14-0  
Fax: (49/7031)14-2999

### ITALY

Hewlett-Packard Italiana  
S.p.A.  
Via Giuseppe di Vittorio, 9  
20063 Cernusco sul Naviglio,  
Milan  
Italy  
Tel: (39/2)921 001  
Fax: (39/2)921 044 73

### UNITED KINGDOM

Hewlett-Packard Ltd.  
Nine Mile Ride  
Wokingham, Berkshire RG11  
3LL  
England  
Tel: (44/344)773100  
Fax: (44/344)763526

### AUSTRALASIA REGION

Hewlett-Packard Australia Ltd.  
31-41 Joseph Street  
Blackburn, Victoria 3130  
Australia  
Tel: (61/3)895-2895  
Fax: (61/3)898-7831

### CANADA

Hewlett-Packard (Canada)  
Ltd.  
6877 Goreway Drive  
Mississauga, Ontario L4V 1M8  
Canada  
Tel: (1/416)678-9430  
Fax: (1/416)678-9421

### FAR EAST REGION

Hewlett-Packard Asia Ltd.  
22nd Floor  
West Tower, Bond Centre  
89 Queensway, Central  
Hong Kong  
Tel: (852)848-7777  
Fax: (852)868-4997

### JAPAN

Yokogawa-Hewlett-Packard  
Ltd.  
3-29-21, Takaido-Higashi  
Suginami-Ku, Tokyo 168  
Japan  
Tel: (81/3)331-6111  
Fax: (81/3)331-6631

### LATIN AMERICA REGION

HP Mexico, S.A. de C.V.  
Monte Pelvoux No. 111  
Fracc. Lomas de Virreyes  
11000 Distrito Federal  
Mexico  
Tel: (52/5)202 01 55  
Fax: (52/5)540 42 08

### EASTERN U.S.A. REGION

Hewlett-Packard Company  
4 Choke Cherry Road  
Rockville, MD 20850, USA  
Tel: (1/301)670-4300  
Fax: (1/301)670-4531

### MIDWEST U.S.A. REGION

Hewlett-Packard Company  
5201 Tollview Drive  
Rolling Meadows, IL 60008,  
USA  
Tel: (1/708)255-9800  
Fax: (1/708)259-4995

### SOUTHERN U.S.A. REGION

Hewlett-Packard Company  
2015 South Park Place  
Atlanta, GA 30339, USA  
Tel: (1/404)955-1500  
Fax: (1/404)980-7669

### WESTERN U.S.A. REGION

Hewlett-Packard Company  
5161 Lankershim Blvd.  
N. Hollywood, CA 91601-  
3794,  
USA  
Tel: (1/818)505-5600  
Fax: (1/818)505-5875

### OTHER INTERNATIONAL AREAS

Hewlett-Packard Company  
3495 Deer Creek Road  
Palo Alto, CA 94304-1316,  
USA  
Tel: (1/415)857-5027  
Fax: (1/415)857-7045



Copyright © 1993  
Hewlett-Packard Co.  
Printed in USA 3/93

Customer  
Reorder No.  
08485-90001

**Manufacturing  
Part No.  
08485-90001**



\*08485-90001\*